



# **COPPER-FIN<sup>2</sup>**

**Gas Heaters  
For Commercial  
Pool Applications**

**High Efficiency In A Space-Saving Design**



**From 500,000 to 2,070,000 Btu/hr  
Up to 89% Thermal Efficiency  
Less Than 30 ppm NOx Rating**



**MULTI-  
STACK**

# COPPER-FIN<sup>2</sup>® Commercial Gas Heaters

## Thermal Efficiency Is Higher...While Footprint And Vent Sizes Are Smaller

Lochinvar's Copper-Fin<sup>2</sup>® line of high efficiency commercial gas heaters gives you all the advantages of copper-finned tube heat exchanger technology plus the benefits of a sealed combustion system. Every Copper-Fin<sup>2</sup> model offers four major advantages: higher efficiency, smaller footprint, smaller vent diameters and a wide variety of venting options.

## Outstanding Thermal Efficiency

Copper-Fin<sup>2</sup> gas heaters offer a remarkably high 89% thermal efficiency. This means that 89¢ out of every fuel dollar goes into heating the water, dramatically reducing the operating cost of the equipment. Copper-Fin<sup>2</sup> achieves this efficiency through the combination of an advanced fan assisted combustion system and an exclusive gasketless copper-finned tube heat exchanger. A time tested and proven combination.



The heat energy from the combustion process is efficiently transferred into the water as it passes through the solid copper-finned tube heat exchanger. The sealed combustion design of the Copper-Fin<sup>2</sup> reduces external heat loss. This means that the energy dollars heat the water, not the mechanical room. It also ensures that the jacket stays cooler, providing greater safety and requiring less clearance from combustible walls - just 1" in most cases.

## **NEW!** Automatic Pumped Bypass Standard

All Copper-Fin<sup>2</sup> heaters are equipped with an automatic pumped bypass ensuring proper flow and return water temperatures to the heater resulting in longer life and trouble free operation. The automatic pumped bypass is provided as standard equipment in a horizontal configuration.



A vertical configuration is also available offering the flexibility to meet mechanical room space requirements or piping constraints.

## Meets The Toughest Air Quality Standards



Because of our unique fan-assisted combustion process, the Copper-Fin<sup>2</sup> exceeds today's toughest NO<sub>x</sub> emissions requirements. An independent certification laboratory test gave us a rating of less than 30 ppm — corrected to 3% O<sub>2</sub>. And less NO<sub>x</sub> means a cleaner environment.

## Compact Design - For Installation Ease

The Copper-Fin<sup>2</sup> is compact enough to fit through standard 36" doorways with ease. Even our 2 million Btu/hr model is only 33-1/2" wide. This space-saving design frees up more space in the mechanical room.



And our optional Multi-Stack™ frame lets you put two units in the footprint of just one. See Multi-Stack frame literature for more details.

## Making Installation Easier...For Less

High-efficiency, fan-assisted combustion means you can use a smaller diameter vent stack — up to 8" smaller than typically required. This makes installation less expensive and more flexible.

## Vent Cost Savings

Btu/hr INPUT	CONVENTIONAL VENT SIZE	COPPER-FIN <sup>2</sup> VENT SIZE	\$ SAVINGS*
500,000	10"	6"	\$ 657
650,000	12"	8"	\$ 731
750,000	14"	8"	\$ 1,450
990,000	16"	10"	\$ 1,790
1,260,000	16"	12"	\$ 1,463
1,440,000	18"	12"	\$ 2,432
1,800,000	20"	14"	\$ 3,526
2,070,000	22"	14"	\$ 3,738

\*Comparison based on 25' vent system using Type "B" double wall vent material, storm collar and vent cap.

# The Proven Performers

## Service & Installation Ease

All Copper-Fin<sup>2</sup> models offer a service friendly design with gas inlet and shutoff cocks, electrical and EMS connections toward the front of the unit, and a slide out control panel. The referenced gas valve design improves operational performance by monitoring the pressure in the sealed combustion chamber to maintain the optimum air/fuel mixture.



All models feature alternate air inlet connections for greater installation flexibility. This field convertible option provides the ability to connect the air inlet on either the right side

or the rear of the unit. And the built-in air inlet filter reduces maintenance and improves performance by trapping dust and airborne particulates that can foul the burners and blowers.

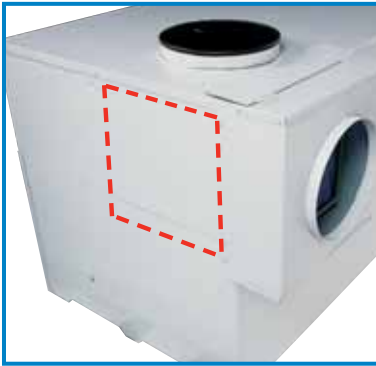

You'll also save installation time and expense with Lochinvar's direct vent option, featuring our innovative Aire-Lock™ combustion system. The Aire-Lock™ direct vent option allows the installer to vent the products of combustion directly through a side

wall without the use of an auxiliary power vent cap. By using approved vent material and an air intake pipe, this option effectively “detaches” the unit from the mechanical room by pulling all combustion air from outside the building and venting all combustion by-products outside through a side wall. A feature that can really simplify an installation while reducing overall installed costs.

## Control at your fingertips

The enhanced operator interface panel provides fingertip control of the built-in digital temperature controller and can



monitor up to four temperature readouts; inlet, outlet, pool and system temperature with the ability to adjust pool temperature. Its refined user friendly design simplifies service by providing “slide-out” access to electronics and controls.

## Flexible Venting Options

### Conventional

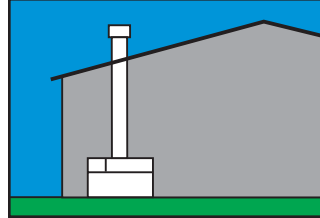

*Vents into conventional flue or vent breaching using Type B double wall vent.*

### Outdoor

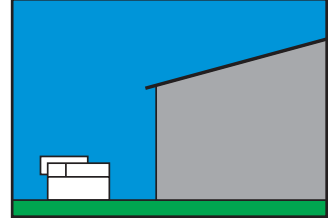

*Requires optional outdoor vent cap. Use when indoor space is a problem or if outdoor location gives better access.*

### DirectAire Vertical with Sidewall Inlet

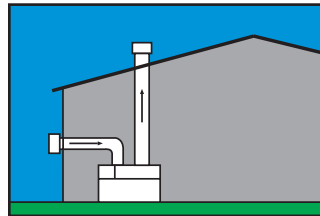

*Draws fresh air from outside and vents through conventional vertical flue.*

### DirectAire Vertical

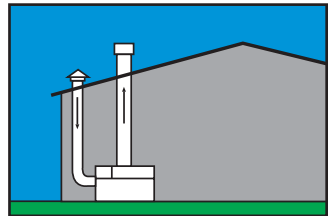

*Draws fresh air from outside and vents through conventional vertical flue.*

### Sidewall (CP501 - 751)

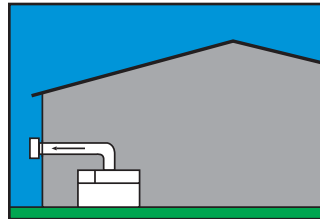

*Draws fresh air from inside the room. Vents up to 50 equivalent feet directly through the outside wall without the need for a powered sidewall cap.*

### Aire-Lock Direct Vent

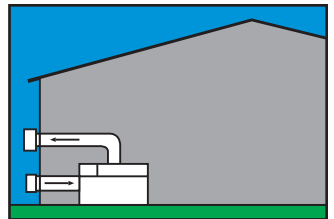

*Utilizes sealed Aire-Lock combustion system to draw fresh air 50 equivalent feet from a sidewall. Vents horizontally up to 50 equivalent feet through the sidewall using Category IV approved vent material.*

### Power DirectAire Horizontal

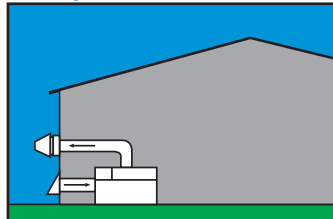

*Draws fresh air from outside and vents through sidewall using optional powered vent cap.*

### Power Sidewall

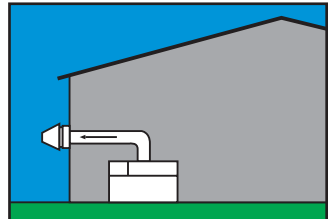

*Vents directly through the outside wall using an optional powered sidewall cap. Ideal when a vent stack is not practical.*

# COPPER-FIN<sup>2</sup> Commercial Gas Heater Dimensions & Specifications

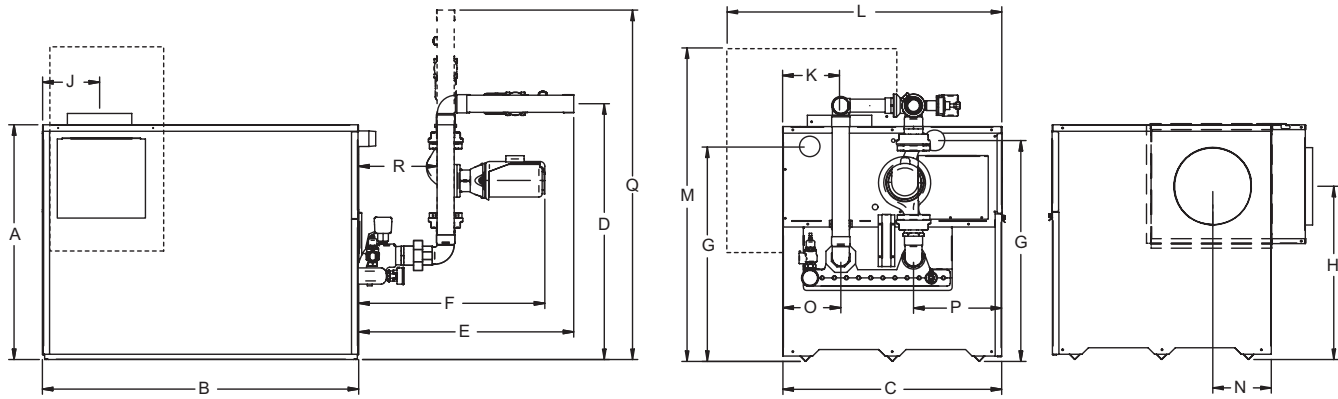

Model Number	Btu/hr Input	Btu/hr Output	A	B	C	D	E	F	G	H	J	K	L	M	N	O	P	Q	R	Vent Size	Air Inlet	Gas Conn	Shipping Weight
CPN501	500,000	445,000	31-1/2"	45-1/2"	22-1/4"	28"	31"	23-1/4"	29"	23"	7"	7"	28"	38"	8"	6"	4-3/4"	44"	9-1/4"	6"	6"	1-1/4"	480
CPN651	650,000	578,500	31-1/2"	56-3/4"	22-1/4"	28"	31"	23-1/4"	29"	23"	8-1/2"	8-1/4"	38"	38"	8"	6"	4-3/4"	44"	9-1/4"	8"	8"	1-1/4"	550
CPN751	750,000	667,500	31-1/2"	64"	22-1/4"	28"	31"	23-1/4"	29"	23"	8-1/2"	8-1/4"	38"	38"	8"	6"	4-3/4"	44"	9-1/4"	8"	8"	1-1/4"	605
CPN0991	990,000	881,100	36"	48-1/4"	33-1/2"	39-1/4"	33"	28-1/2"	34"	27"	8"	9-1/4"	42"	48"	9-1/4"	2-3/4"	14-1/2"	51-1/2"	12"	10"	10"	2"	930
CPN1261	1,260,000	1,121,400	36"	58-1/2"	33-1/2"	39-1/4"	33"	28-1/2"	34"	27"	9"	10-1/4"	42"	48"	9-1/4"	2-3/4"	14-1/2"	51-1/2"	12"	12"	12"	2"	995
CPN1441	1,440,000	1,281,600	36"	68-3/4"	33-1/2"	39-1/4"	33"	28-1/2"	34"	27"	9"	10-1/4"	42"	48"	9-1/4"	2-3/4"	14-1/2"	51-1/2"	12"	12"	12"	2"	1,130
CPN1801*	1,800,000	1,602,000	36"	82-1/4"	33-1/2"	39-1/4"	33"	28-1/2"	34"	27"	10"	11-1/2"	42"	48"	9-1/4"	2-3/4"	14-1/2"	51-1/2"	12"	14"	12"	2"	1,285
CPN2071*	2,070,000	1,842,300	36"	92-1/2"	33-1/2"	39-1/4"	33"	28-1/2"	34"	27"	10"	11-1/2"	42"	48"	9-1/4"	2-3/4"	14-1/2"	51-1/2"	12"	14"	12"	2"	1,400

Notes: Change 'N' to 'L' for LP gas models.

No deration on LP models.

Performance data is based on manufacturer test results.

\*Cupro Nickel Heat Exchanger is standard on these models.

Water connections for models (CP 501-751) are 2" NPT on 11-1/2" centers.

Water connections for models (CP 0991-2071) are 2-1/2" NPT on 16-1/4" centers.

If flanged connections are selected overall piping dimensions changes.

Consult factory if critical.

## Standard Features

- Up to 89% Thermal Efficiency
- Digital Operator Interface
- Less Than 30 ppm NOx Rating
- ASME Gasketless Copper-Finned Tube Heat Exchanger (CP501-1441)
- ASME Gasketless Cupro Nickel Finned Tube Heat Exchanger (CP1801-2071)
- Automatic Pumped Bypass
- Loch-Heat™ Ceramic Tile Sealed Combustion Chamber
- Combustion Air Filter
- Field Convertible Air Inlet Connection
- Programmable Temperature Setpoint
- Inlet & Outlet Temperature Sensor
- Pool Temperature Sensor
- Hot Surface Ignition System
- Stainless Steel Burners
- Referenced Gas Valves
- ASME 160 psi Working Pressure
- 110°F Safety Limit
- 24V Controls
- Flow Switch
- Air Pressure Switch
- Remote Control Compatible

- Adjustable High Limit w/ Manual Reset
- 150 psi ASME Temperature and Pressure Relief Valve
- Slide-Out Control Panel with Plug-In Components
- 5-Year Limited Warranty on Heat Exchanger (See warranty for details)

## Optional Equipment

- Alarm Bell
- Cupro Nickel Heat Exchanger (CP501-1441)
- Flanged Inlet/Outlet Fittings
- Multi-Stack Frame (Horizontal Bypass Only)
- Pump Delay
- Pump Purge w/ Maintenance Timer
- Vertical Mounted Pumped Bypass

## Available Firing Systems

- F9 Electronic Control with Hot-Surface Ignition (Standard)
- F13 Factory Mutual (FM)
- F7 California Code

## Venting Options

- Aire-Lock Direct Vent Sealed Combustion
- Conventional
- DirectAire® Vertical
- DirectAire Vertical w/ Sidewall Inlet
- Outdoor
- Powered DirectAire Horizontal
- Powered Sidewall
- Sidewall (CP501-751)

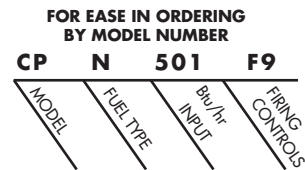

This heater is 500,000 Btu/hr natural gas Copper-Fin2 pool heater. It has F9 firing controls.



**Lochinvar**  
High Efficiency Water Heaters, Boilers and Pool Heaters



Lochinvar Corporation • 300 Maddox Simpson Pkwy • Lebanon, TN 37090 • 615-889-8900 / Fax: 615-547-1000

[www.Lochinvar.com](http://www.Lochinvar.com)